

FED. ROAD DIST. NO.	STATE	JOB PIECE NO.	FISCAL YEAR	SHEET NO.	TOTAL SHEETS
6	OKLA.	27050(04)	2017		

DESCRIPTION	REVISIONS	DATE

NOTE: FENCE DETAILS SHOWN ON THIS SHEET SHALL BE USED TO CONSTRUCT FENCE ALONG FT. SILL MILITARY RESERVE. NEW FENCE SHALL BE CONSTRUCTED AND PERIMETER SECURED PRIOR TO REMOVAL OF EXISTING FENCE.

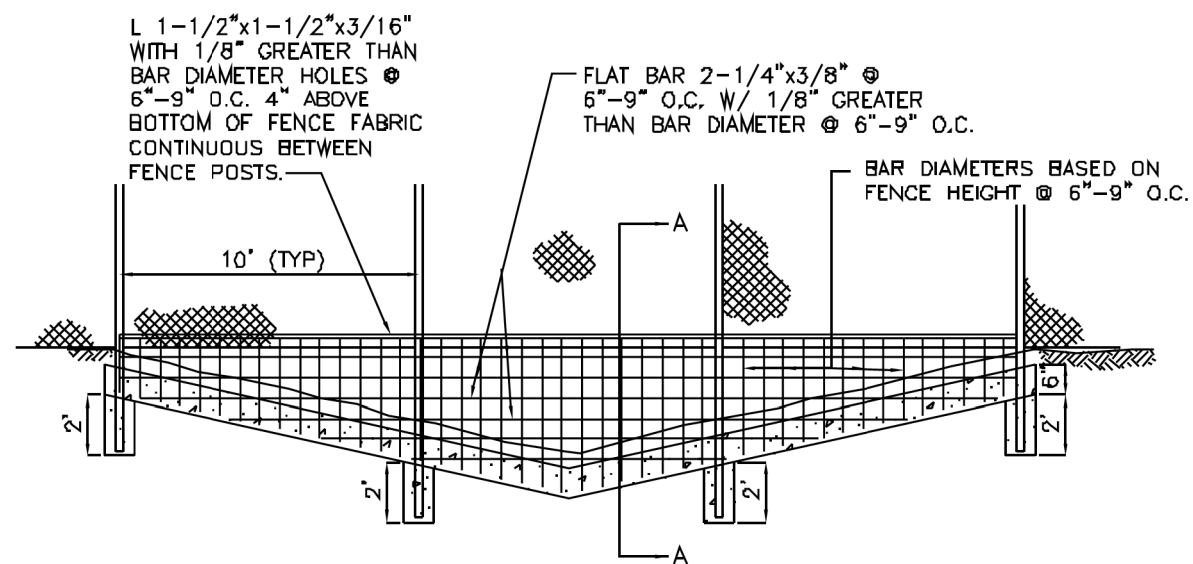

**FENCE SECURITY BARRIER\***  
NO SCALE

\* MAY VARY DUE TO FIELD CONDITINS

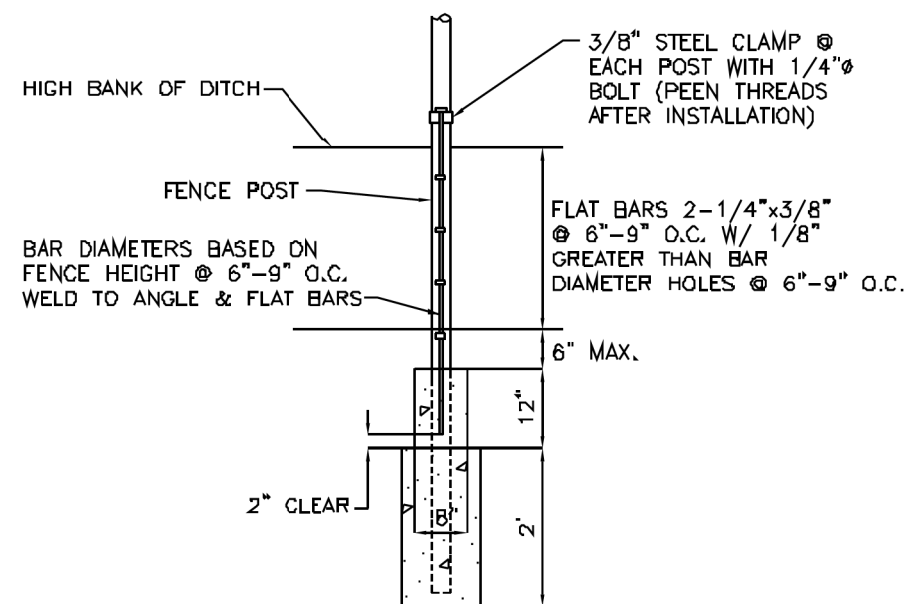

**SECTION A-A**  
NO SCALE

DESIGN	AKS	6/14	1-44 & US-62 INTERCHANGE
DRAWN	BWH	6/14	
CHECKED	JES	5/18	
APPROVED			
SQUAD	<b>GARVER</b>		

MISCELLANEOUS DETAILS  
(SHEET 3 OF 3)

STATE JOB NO. 27050(04) SHEET NO. 9